

R40 Cylinder Test Console

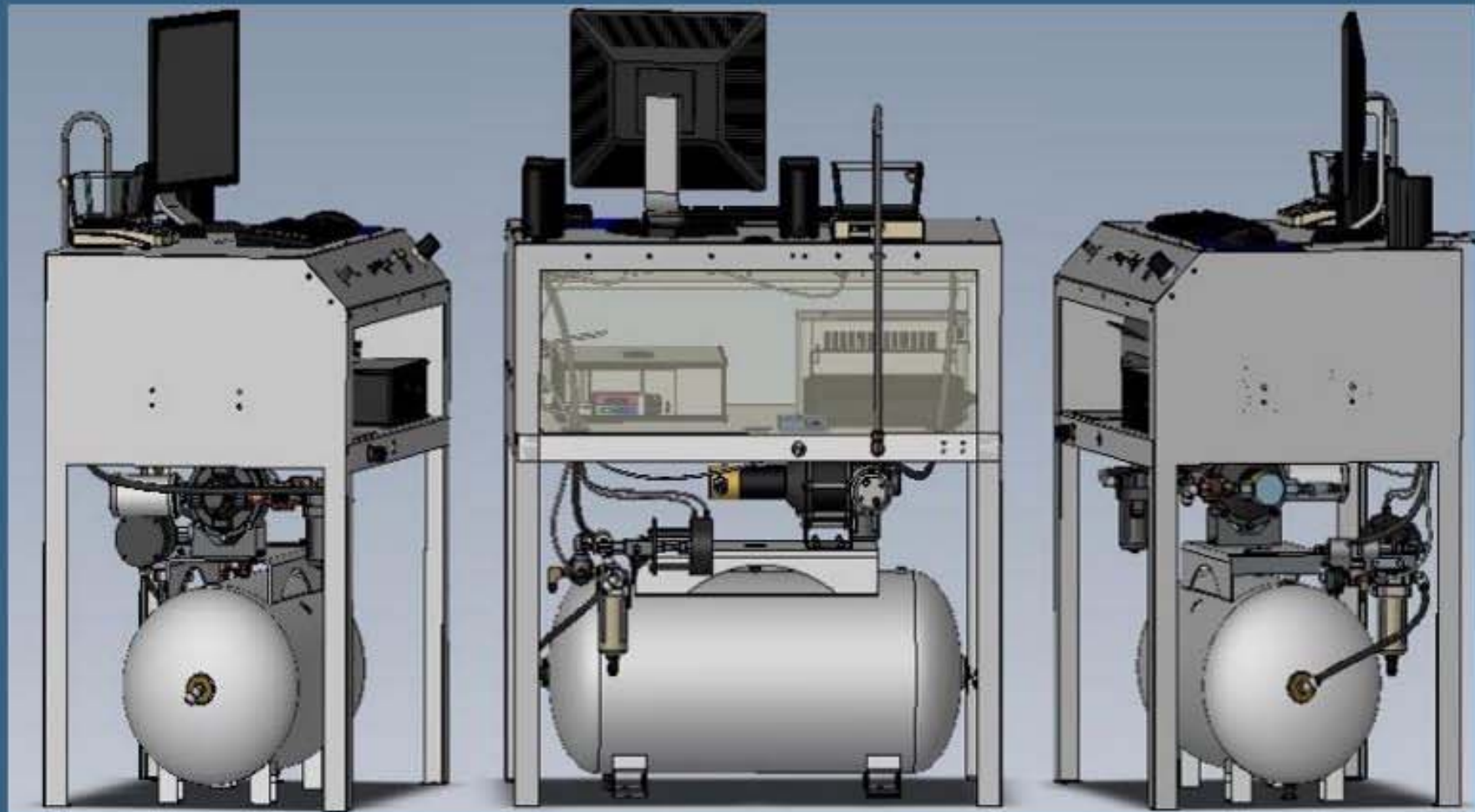

- The RECORTEST 4 OPEN(R40) will test up to 20 cylinders per hour when manned by an experienced operator with 2 Test jackets
- Operator is free to perform other tasks or prepare another cylinder for the next test while automated tests are being performed
- Test system, Calibrated Cylinder, and Master Gauge pressures values in BAR/PSI
- High reliability digital instruments for pressure and expansion measurements provide superior accuracy.
- Remote - capability to operate, service and support networked R40 systems worldwide from office in USA
- Visual and/or audible system notifications of errors, alerts, cylinder pass/fail and safety issues. Automatic e-mail notification of the above.
- Network capable – System can be set to export data remotely to workgroup or central database.
- 19" flat panel monitor, Dell computer, and laser printer
- Windows 7 based software

- Options:**
- Dual Jacket**
 - Direct Expansion**
 - Double Acting Pump**
 - Slow Pump**
 - CE Marking**

GALISO
INCORPORATED
GASES LIQUIDS SOLIDS
22 Ponderosa Ct
Montrose, CO 81401
www.galiso.com (800)854-3789

- Dimensions Console 26" L x 40" W x 56" H
- Electrical Requirements 110v or 220Volts, 50/60 Hz
- Water..... City Water Pressure
- Air 120 PSI, 10 CFM
- Cylinder Expansion Measurement..... Standard 800cc Available to 30,000cc +
- Pump..... Standard 10,000psi Available in 1,000 - 50,000psi

