

# GTC Test Console

02-51-2022

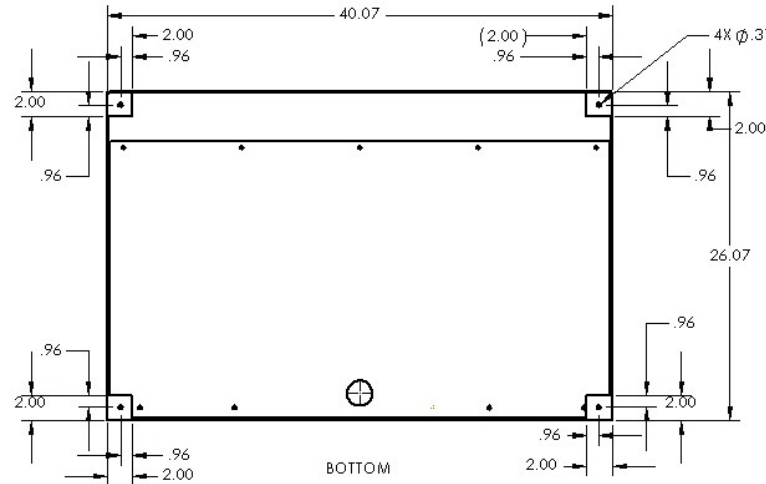
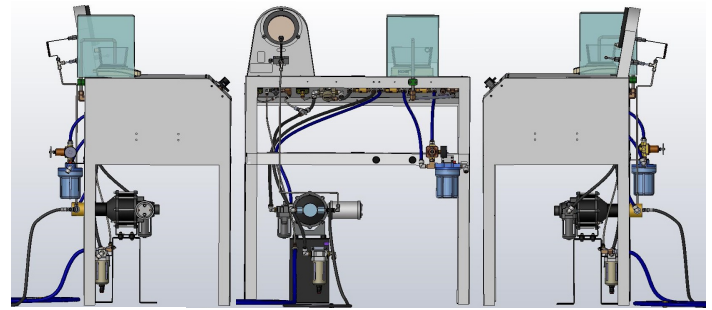
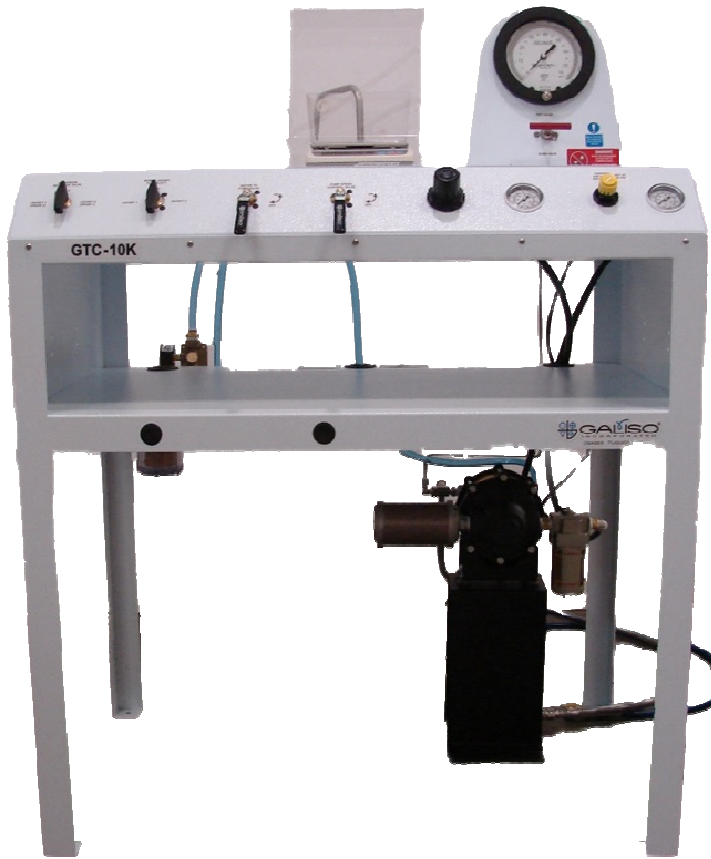

Dimensions ..... 26" L x 40" W x 56" H

- Expansion measured with electronic accuracy to 1/10 CC by the EEMS (Electronic Expansion Measuring System) system by LCD display.
- Can be configured to a 1 or 2 test jacket system
- Tests to pressures up to 10,000pi.
- Use for Steel, Aluminum, Composite Exemption cylinder testing.
- Highly reliable air driven intensifier pump.
- No cost operator training at the Galiso facility.
- One year warranty. Extended to 18 months when installed by a Galiso Field Service Technician



PO Box 1468  
 Montrose, CO 81401  
[www.galiso.com](http://www.galiso.com) (800)854-3789

(Scale) Electrical - 3 Amps @ 220Volts, 50/60 Hz  
 Capacity 1200g x .1 Resolution

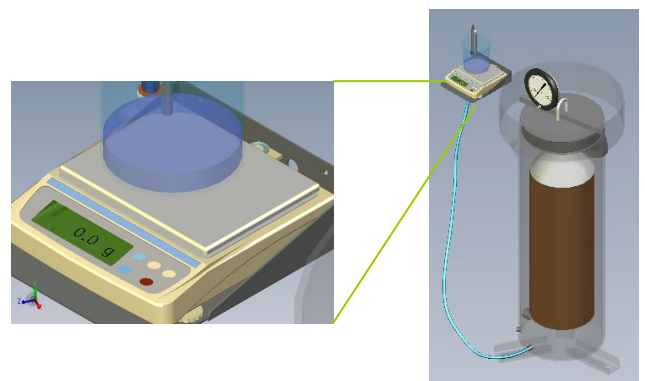
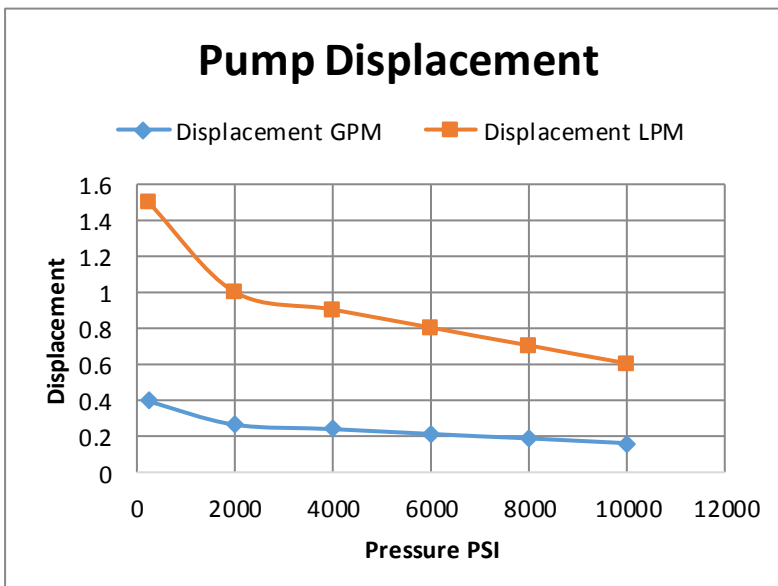

Air Supply  
 Full Duty Cycle GTC 28 CFM  
 Pressure: 90-120PSI/6.2-8.2Bar

Installation:  
\*\*\*\*See VIDEO\*\*\*\*

Training:  
\*\*\*\*See VIDEO\*\*\*\*