

GTC Test Console

02-51-2013

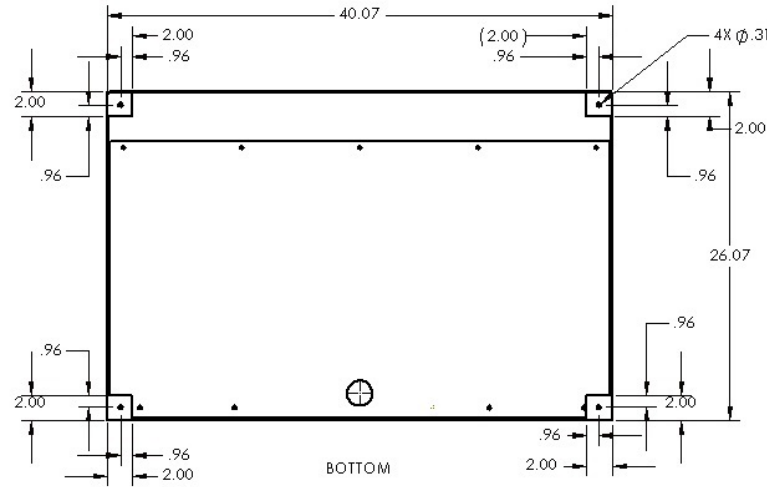
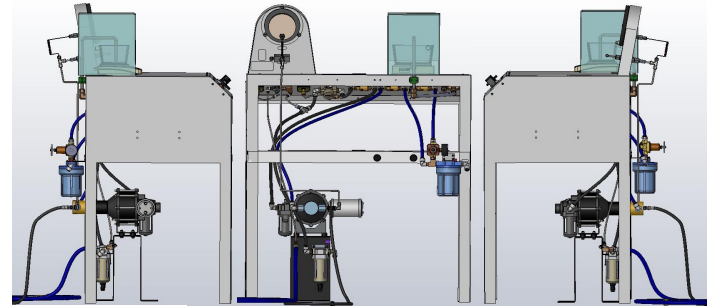
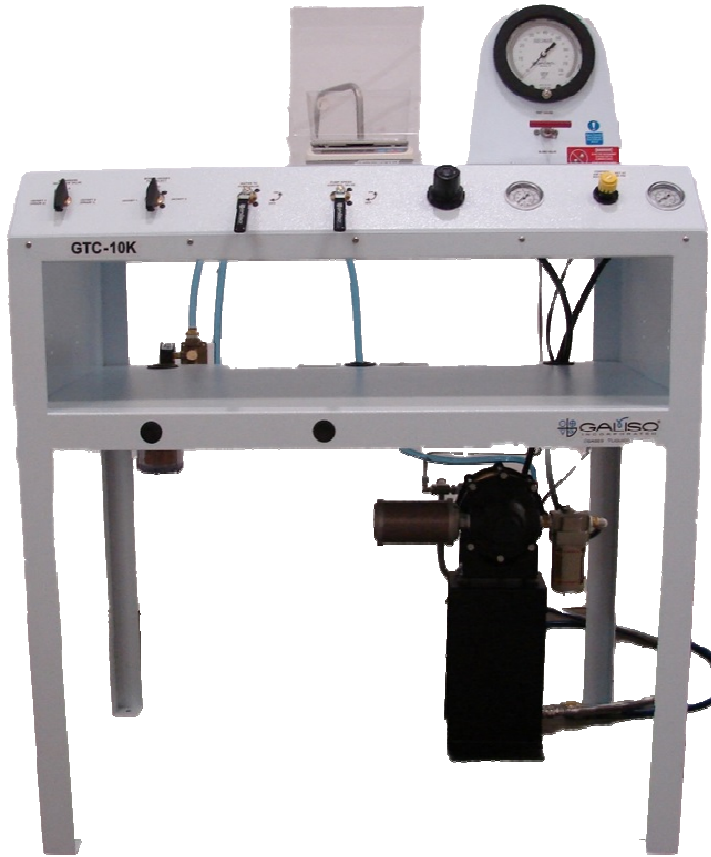

Dimensions 26" L x 40" W x 56" H

- Expansion measured with electronic accuracy to 1/10 CC by the EEMS (Electronic Expansion Measuring System) system by LCD display.
- Can be configured to a 1 or 2 test jacket system
- Tests to pressures up to 10,000psi.
- Use for Steel, Aluminum, Composite Exemption cylinder testing.
- Highly reliable air driven intensifier pump.
- No cost operator training at the Galiso facility.
- One year warranty. Extended to 18 months when installed by a Galiso Field Service Technician



PO Box 1468
 Montrose, CO 81401
www.galiso.com (800)854-3789

(Scale) Electrical - 5 Amps @ 110Volts, 50/60 Hz
 Capacity 1200g x .1 Resolution

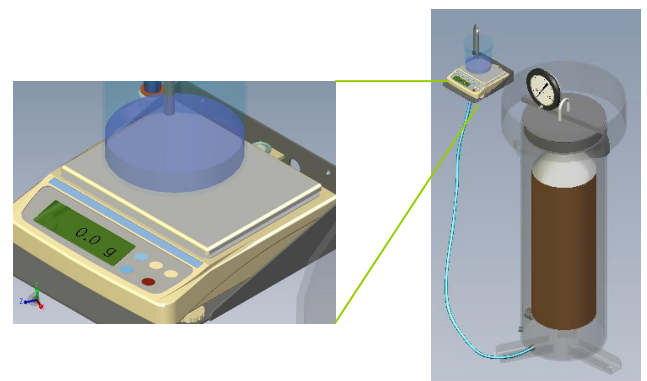
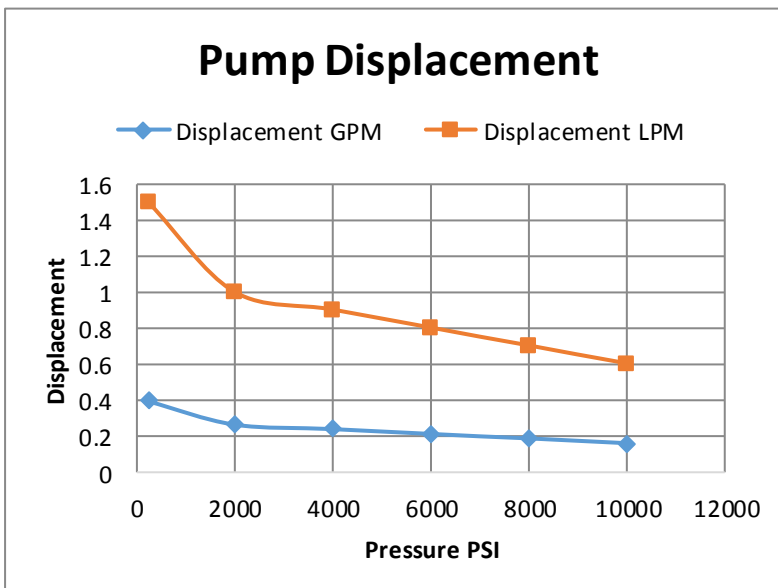

Air Supply
 Full Duty Cycle GTC 28 CFM
 Pressure: 90-120PSI/6.2-8.2Bar

Installation:
****See VIDEO****

Training:
****See VIDEO****