



!!!DANGER!!!

**DO NOT USE THIS EQUIPMENT TO
PURGE TOXIC OR FLAMMABLE GAS**

AND

**DO NOT USE THIS EQUIPMENT UNDER
FLAMMABLE, VOLATILE OR TOXIC
ENVIRONMENTAL CONDITIONS**

PPT SERIES

Proof Pressure Test Console, Hydrostatic

INSTRUCTION MANUAL

Proof Pressure Tester, (PPT)

01-51-8550 = 1,200 PSI

01-51-8562 = 3,000PSI

01-51-8558 = 10,000 PSI



MANUAL NUMBER 21-11-1072

Copyright 1997, Galiso Inc.
22 Ponderosa Ct., Montrose, CO 81401
(970) 249-0233 (800) 854-3789
www.galiso.net

Revision C Issued Aug, 2004

TABLE OF CONTENTS

Section/Title	Page
1.0 Introduction	1-1
1.1 Hydrostatic Testing	1-1
2.0 System Components & Specifications	2-1
2.1 PPT Console Specifications	2-1
2.2 PPT Console Options	2-2
3.0 Safety	3-1
3.1 Personnel Safety.....	3-1
3.2 Equipment Precautions.....	3-1
4.0 Installation	4-1
4.1 Receiving	4-1
4.2 Placement.....	4-1
4.3 Facility Requirements	4-1
4.4 Utility Connections	4-1
4.5 Plumbing Installation.....	4-2
4.6 Hose Preparation.....	4-3
4.7 Preparations for Testing	4-3
5.0 Operations.....	5-1
5.1 Precautions	5-1
5.2 System Start-up	5-1
5.3 Cylinder Preparation	5-3
5.4 Air Regulator Settings.....	5-5
5.5 Cylinder Test Connections & Procedure.....	5-5
6.0 Maintenance and Calibration	6-1
6.1 PPT Console.....	6-1
6.2 Intensifier Pump Assembly	6-1
6.3 Troubleshooting	6-1

TABLE OF CONTENTS

(continued)

Attachments:

1. Warranty Terms
2. Drawings
3. Vendor Equipment OEM Literature

Data Sheets:

1. Cylinder Hydrostatic Test Log

List of Tables and Figures

Number/Title	Page
2.1 PPT Console	2-1
3-1 Hydraclose Seal	3-2
3-2 Cylinder Neck Thread Detail	3-3
4-1 PPT Console Plumbing	4-2
5-1 Pump VS Air Pressure Graph - Low Pressure	5-2
5-2 Pump VS Air Pressure Graph - High Pressure	5-3
6-1 PPT Console	6-2
Table 2-1 PPT Options (Model Numbers)	2-2
Table 4-1 Field Plumbing Connections	4-3
Table 5-1 Pump Specifications	5-2
Table 6-1 Troubleshooting	6-1

1.0 INTRODUCTION

The PPT Hydrostatic Test Console is designed to meet the needs of the low volume cylinder re-qualification facility. It is ideal for Fire Extinguisher, SCBA and SCUBA cylinder re-qualification. However, the PPT may be used to re-qualify up to 100 pound CO₂ size cylinders.

The manually operated PPT Test Console includes the following features:

- Standard Test Pressures up to 10,000 psi, with an accuracy of plus or minus 1% at 2,000 psi.
- An Air Driven Intensifier Pump
- A Table with Gauge Face Panel
- A convenient Desk Top Shelf which provides a writing area for recording test data and results on the test log.
- Floor Lagging Clips
- An Optional Test Pressure Recorder is available.

1.1 Hydrostatic Testing

In accordance with D.O.T./T.C. regulations, certain cylinders must be periodically re-qualified and certified safe for use. The re-qualification procedure and regulations are discussed in detail in the Code Of Federal Regulation (CFR), Title 49, Section 173.34. Copies of the CFR may be obtained from Galiso or by writing to the following address:

**Superintendent of Documents
U.S. Government Printing Office
Washington, D.C. 20402**

2.0 PPT SYSTEM COMPONENTS AND SPECIFICATIONS



Figure 2- 1 PPT Console

2.1 PPT Console Specifications:

- Test Stand Dimensions: Height: 60 Inches Width: 27 Inches Length: 20.5 Inches
- Air Requirements: A minimum of 10 cfm Shop Air at 100 psig (intermittent)
- Water Requirements: City Water at a minimum of 10 PSI

2.2 PPT Console Options

The PPT model test console is available in three test pressure ranges. The available options are shown in Table 2-1, below.

Table 2 - 1 PPT Console Options

Model Number	Part Number	Max. Test Pressure
PPT-1200	01-51-8550	1,200 PSI
PPT-3000	01-51-8562	3,000 PSI
PPT-10000	01-51-8558	10,000 PSI

3.0 SAFETY

Read all instructions before attempting to install or operate the PPT Console. **GALISO, INC. IS NOT RESPONSIBLE FOR DAMAGE OR INJURY CAUSED BY UNSAFE USE, MAINTENANCE OR APPLICATION OF THIS MACHINE.** Please contact Galiso for guidance when you are in doubt as to the proper safety precautions to be taken when installing or operating this machine.

3.1 Personnel Safety

- 3.1.1 Always double check the cylinder pressure rating stamped on the cylinder shoulder to determine the required test pressure.



**DO NOT OVER-PRESSURIZE CYLINDERS
CYLINDER OVER-PRESSURIZATION CAN CAUSE SEVERE EQUIPMENT DAMAGE AND
RESULT IN PERSONNEL INJURY OR DEATH**

- 3.1.2 Galiso, Inc. recommends installation of a safety barrier which isolates the test vessel (cylinder) from all personnel while testing is in progress. The safety barrier must be capable of protecting personnel in the event of a catastrophic test vessel failure. All personnel must stay clear of the test vessel during testing.
- 3.1.3 Do not handle the test pressure hose while the test vessel is pressurized. Injury could occur due to hose leaks.
- 3.1.4 When releasing the pressure from the test vessel at the completion of testing always open the Bleed/Vent Valve slowly to avoid sudden high energy pressure releases.
- 3.1.5 Do not attempt to remove the test connection prior to verifying that the test vessel has been completely de-pressurized.
- 3.1.6 Always wear eye protection and gloves when using the system.

3.2 Equipment Precautions

- 3.2.1 Before connecting a cylinder for testing, inspect the cylinder neck threads. Cylinders with excessively worn or damaged neck threads must be dispositioned in accordance with CGA Pamphlets C-6, 6.1 or 6.2 as appropriate.
- 3.2.1 Before connecting a test vessel (cylinder) for testing, check the test pressure hose and fittings to ensure they are in proper working order.
- 3.2.2 The test spud (see figure 3-1) must engage the cylinder neck threads with at least four threads for the cylinder to be safely tested. If the test connection is not properly attached to the cylinder, it could be blown off during pressurization. If there is any question about the test connection **do not test the cylinder.**

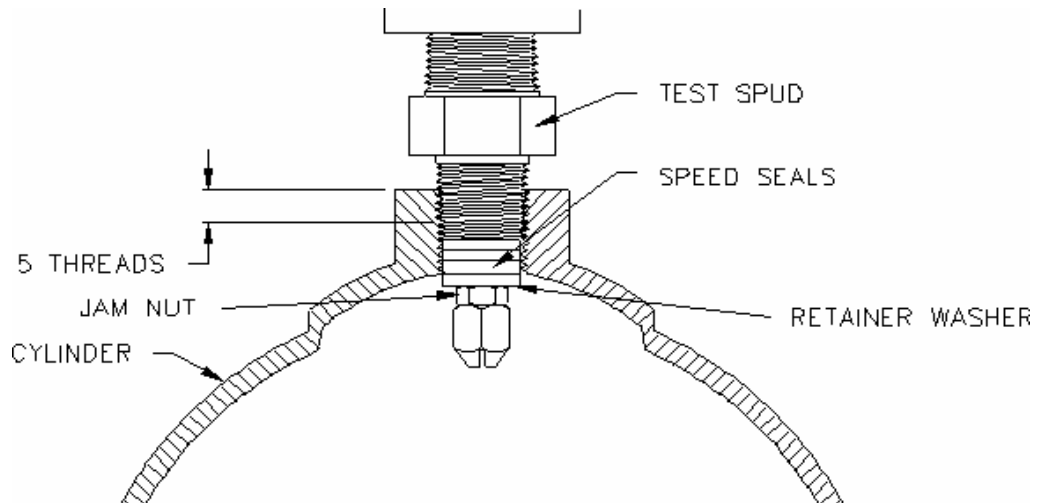
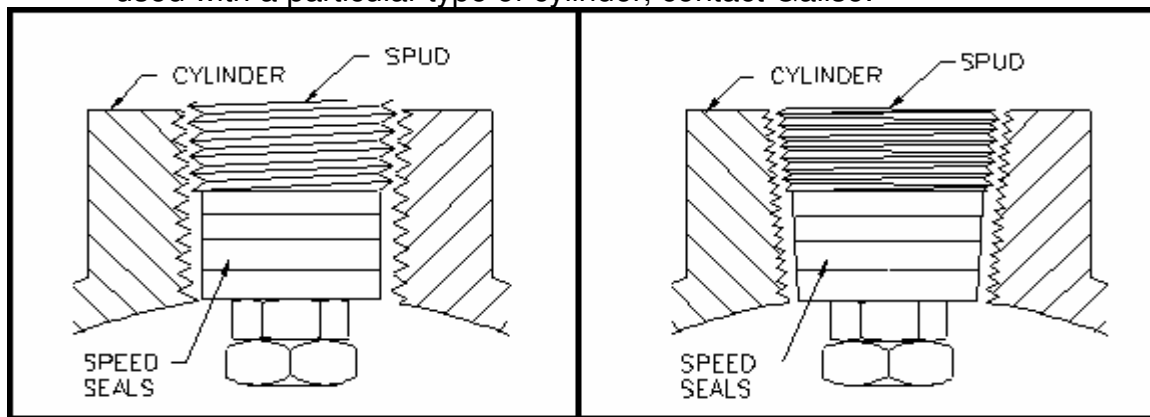

Figure 3 - 1 Hydraclose Seal

3.2.4 Make certain that you are using a test spud that is appropriate for the neck threads of the cylinder that is being tested (see figure 3-2 below). When an incorrect test spud is screwed on to certain types of cylinders (such as Linde cylinders with oversize neck threads or Airco cylinders with double tapered neck threads), the cylinders will appear firmly attached, but they do not properly engage the threads of the test spud. If you have any questions concerning the appropriate test spud to be used with a particular type of cylinder, contact Galiso.



Oversize Thread

Double Taper Thread

Figure 3 - 2 Cylinder Neck Thread Detail

3.2.5 Before pressurizing a cylinder, adjust the air pressure regulator to the intensifier pump to prevent cylinder over-pressurization. For example, if the cylinder test pressure is 500 psig, adjust the air pressure regulator to stall the pump at approximately 550 to 600 psig. See section 5.4.1.B for additional information regarding pump output pressure adjustment.

3.2.6 Keep the work area around the PPT Test Console clean, dry and free of debris to reduce the risk of operator injury due to slips or falls.

4.0 INSTALLATION

Read all instructions and familiarize yourself with the installation drawings before attempting to install or operate the PPT Console.

4.1 Receiving

Carefully un-crate the PPT Console and remove all banding and padding materials.

and Table 4-1 for information if the lines have been disconnected. Contact Galiso, Inc. immediately if damaged items are identified.

4.2 Placement

Select an area to install your PPT Console. The installation location should allow sufficient drainage to prevent water from accumulating around the test system. Refer to the installation drawings supplied with this manual. Detail the flow of cylinders through the test area. Take care not to install your system in such a manner that would inhibit or cause interruptions in the flow of cylinders. If you need help with this, send a detailed drawing of your shop floor to Galiso for suggestions.

4.3 Facility Requirements

Construct a suitable safety barrier, & locate the PPT Console in a convenient location. We recommend you bolt the Test Stand and Pump Skid securely to the floor.

4.4 Utility Connections

Familiarize yourself with the Water and Air plumbing required for the PPT Test System. Carefully consider your individual system layout and plan the route of each plumbing line.

Connect a 100 psig shop air supply to the PPT Console at the location labeled "Shop Air In". Connect a water supply to the PPT Console. The utility service connection locations are shown in figure 4-2.

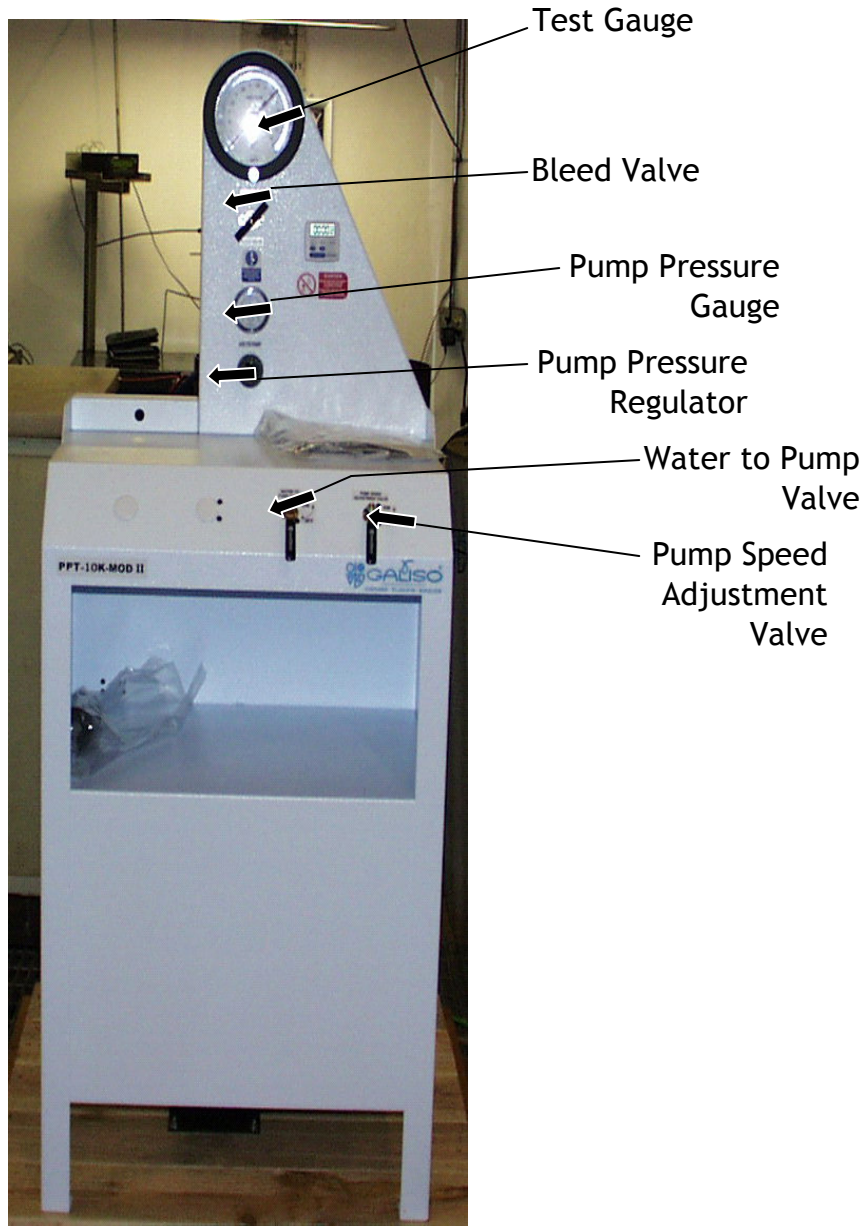

Figure 4 - 1 PPT Console Controls

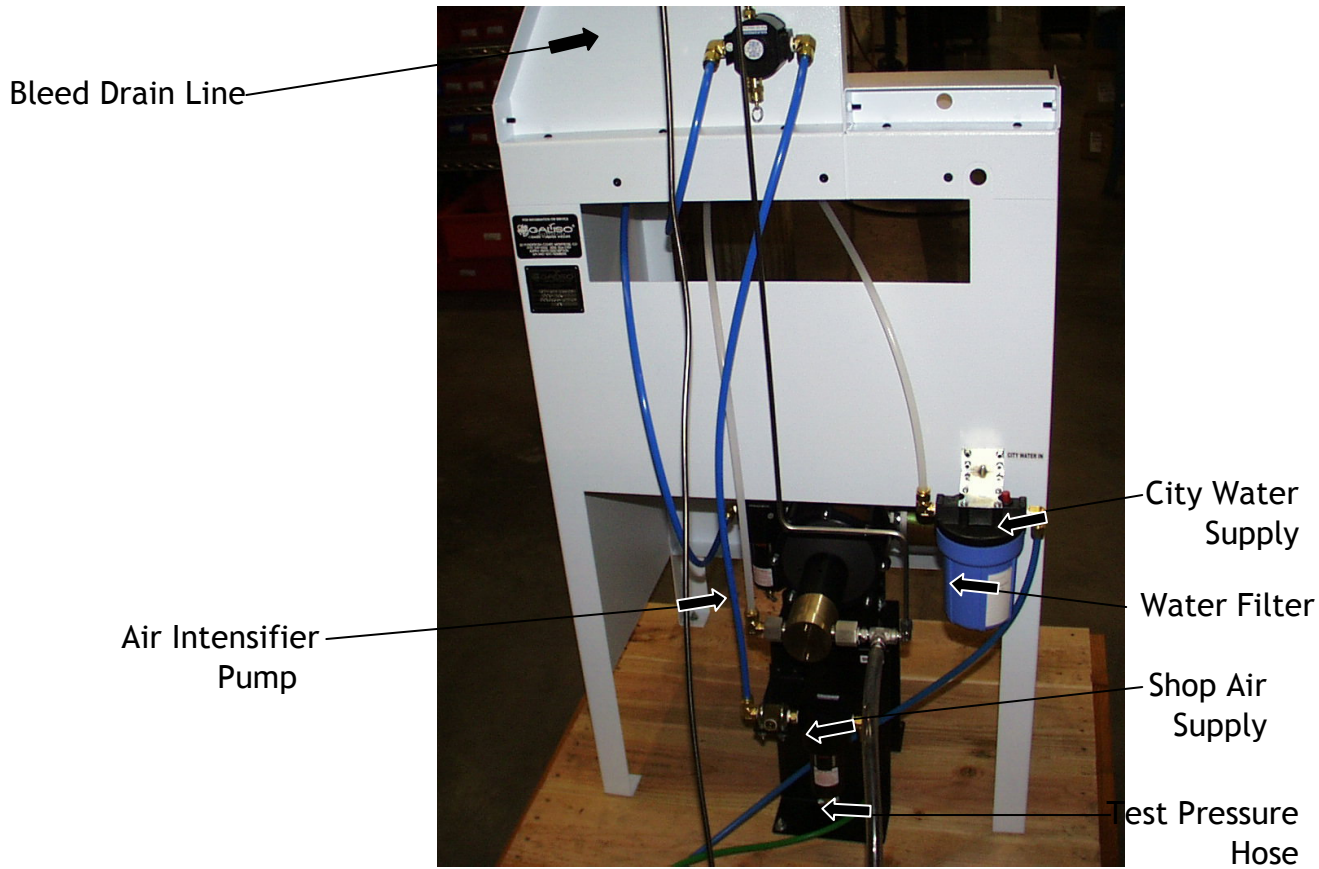

Figure 4-2 PPT Console Plumbing, Rearview

4.5 Plumbing Installation

In addition to the utility service connections, the following additional plumbing connections must be made:

4.5.1 Bleed Line Plumbing

Route the 1/4" X .065 wall, stainless steel tubing provided, from the bleed valve exhaust to a convenient pit or drain location, see figure 4-2.

Table 4-1 summarizes the required plumbing connections.

Table 4 - 1 Field Plumbing Connections

Line	From	To
Bleed Drain Line (1/4"x.065" SST)	Bleed Valve (1/4" SS CPI)	Pit/Drain
Water Supply	Customer Supply	PPT Water Filter Inlet (3/8" Prestolok)
Air Supply	Customer Supply	PPT Air Filter Inlet (1/2" Prestolok)

4.6 Hose Preparation

Install a water tight adapter to the high pressure hose.

4.7 Preparations for Testing

Recheck the lines and fittings on the PPT Console for tightness.

Turn on the air and water supply to the system. Check the lines for leaks. If leaks are detected, turn off the air and water supplies and tighten the leaking fittings.

The system should now be ready for start-up and checkout. Refer to Section 5.0 of this manual for the necessary operating instructions.

5.0 OPERATIONS

These operating instructions describe procedures required for system start-up and cylinder testing activities.

5.1 Precautions

Proof Pressure testing of cylinders involves the use of high pressure equipment and components. Proof Pressure testing should be performed only by personnel properly trained in Proof Pressure testing and the specific equipment being used.

The water supply should be turned off if the air supply to the system is turned off. The water supply to the system should also be turned off when the system is not in use.

Make certain that you are using a test spud that is appropriate for the neck threads of the cylinder that is being tested. Certain types of cylinders (such as Linde cylinders with oversize neck threads or Airco cylinders with double tapered neck threads) will appear firmly attached when screwed on to an incorrect test spud, without properly engaging the threads of the test spud. If you have any questions concerning the appropriate test spud to be used with a particular type of cylinder, contact Galiso.

Before each starting operation of the PPT Console, a visual check of the system should be made to assure the unit is ready for testing. Check the lines to make certain they are tight and there is no damage.

5.2 System Start-Up

The following Start-Up procedures should be performed before attempting to operate the PPT Console after initial installation or for the first time after water pressure to the unit has remained off for a prolonged period of time.

5.2.1 Cylinder and Test Adapter Installation

Screw the Test Adapter into the cylinder neck, engaging with 3 to 5 neck threads.

5.2.2 Pump Pressure Adjustment

PPT Consoles are supplied with either a low pressure or a high pressure pump depending on the model ordered. Table 5-1 shows the pump specifications for the available PPT Consoles. The pump pressure adjustments are required to ensure that cylinders are not over-pressurized.

Table 5 - 1 Pump Specifications

PPT Model	Pump Type	Press. Ratio	Max. Pump Press.	Remarks
PPT-1200	LP, AZ-1-26	26:1	2625 PSI	Figure 5-1
PPT-3000	LP, AZ-1-30	30:1	3075 PSI	Figure 5-2
PPT-10000	HP, AZ-1-140	140:1	14000 PSI	Figure 5-2

- A. To determine the required air pressure regulator setting, first determine the required cylinder test pressure. Then, find the corresponding air pressure regulator setting using the graph shown in figure 5-1 or 5-2 whichever applies to your test system (see Table 5-1). Alternatively, the required air pressure may be determined by dividing the cylinder test pressure by the pressure ratio value (either 26, 30, or 140) shown in Table 5-1.

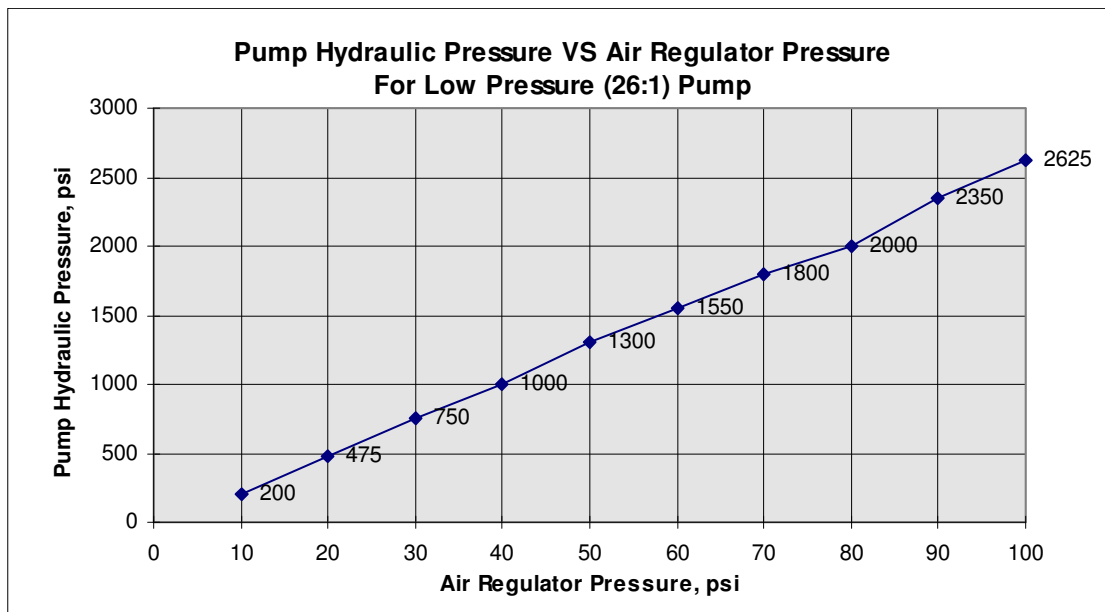

Figure 5 - 1

5.2.2 Pump Pressure Adjustment, continued

- B. Since the values shown in figures 5-1 and 5-2 are approximate, add 5 to 10 psig to the air to pump pressure regulator setting determined from the graph (or from the pressure ratio multiplier) to insure that the pump will not stall out prior to reaching the required test pressure.

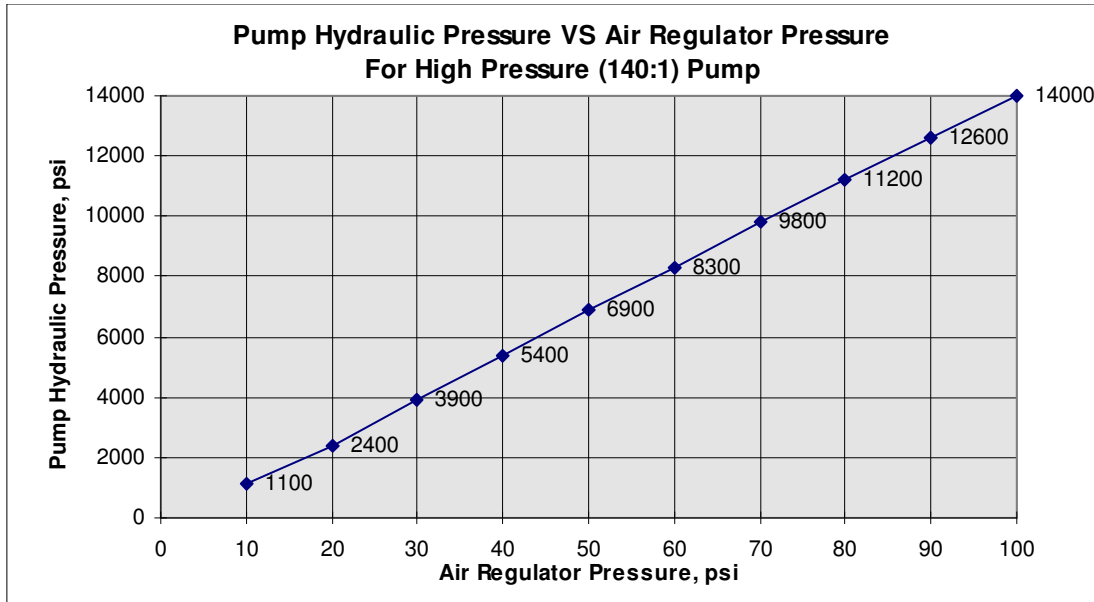

Figure 5 - 2

- C. Adjust the Air To Pump Pressure Regulator to the pressure determined above as indicated on the air to pump regulator pressure gauge, see figure 5-5.

5.3 Cylinder Preparation

Cylinders to be tested must be subjected to an internal and external visual inspection in accordance with CGA pamphlet C-6, 6.1, 6.2, 6.3, & C-8 "Standards for Visual Inspection of Compressed Gas Cylinders".

The exterior of each cylinder should be cleaned of dirt, scale, grease, oil and any other contamination before inspection. The inspector should check the entire exterior surface, including the bottom of the cylinder, for any damage such as dents, arc or torch burns, bulges, serious corrosion or any other damage that could appreciably weaken the cylinder. Any cylinders that do not pass the inspection should be removed from further service.

Each cylinder should be tapped with a 8oz machinist's hammer. If the cylinder has a dull or dead ring, it should be internally cleaned by tumbling or other suitable means. If the dull or dead ring persists after the cylinder has been internally cleaned, the cylinder must be condemned.

WARNING

Do not test obviously defective cylinders. Testing of defective cylinders is a safety hazard and can result in equipment damage, personnel injury or death.

Remove the cylinder valve and tag it with the cylinder serial number so that the valve will be reinstalled in the same cylinder. Cylinder valves generally conform themselves to the particular neck threads of the cylinder in which the valve is first installed and may not seal as well in cylinders with a slightly different neck thread configuration.

If the cylinder has contained a flammable gas it must be washed prior to internal visual inspection. Either fill the cylinder with water and then dump it out, or purge the cylinder with clean, dry air or Nitrogen.

Use a Galiso Opti-Lite, Fiber Optic Inspection Light or low voltage bulb (to prevent the possibility of electrical shock) to inspect the interior of the cylinder per CGA pamphlet C-6, "Standards for Visual Inspection of Compressed Gas Cylinders".

Carefully check the interior of the cylinder for excessive corrosion, dirt, scale, or sludge which must be removed prior to hydrostatic testing. Internal cleaning of the cylinder should be performed prior to hydrostatic testing. Internal cleaning methods such as tumbling with abrasives or shot blasting can slightly weaken the cylinder wall. Cylinders that pass visual inspection should be filled with clean, filtered water.

5.3.1 Cylinder Test Log

The Test Log will list a series of cylinder/test data to be filled out by the operator prior to or during the test for each cylinder to be tested. The following information is required for each cylinder to be tested:

CYLINDER OWNER:

SERIAL NUMBER:

ICC OR DOT Spec. and Service Pressure:

MFG or Symbol and Date.:

SERVICE (CAP./GAS)

CYLINDER SIZE:

VISUAL INSPECTION: Record the results of the Visual Inspection.

TEST PRESSURE: See CGA Pamphlet C-5

Expansion: Total, Permanent, Elastic

5.3.1 Cylinder Test Log (continued)

% Permanent Expansion.

TEST RESULT CODE: Enter the appropriate code:

- A. PASS
- B. FAIL, Visible Defects, See Remarks.
- C. RETESTED, Equipment Failure.

TESTED BY: The test equipment operator's name or initials.

REMARKS: Write in any remarks pertinent to the test in this area.

5.4 Air Regulator Settings

Verify the gauge on the Intensifier Pump regulator indicates the proper air pressure setting for the cylinders to be tested. Refer to Section 5.2.5, Pump Pressure Adjustment, for instructions.

5.5 Cylinder Test Connections & Procedure

Verify that the Water To Pump Valve is in the OFF position and the Bleed Valve handle is securely in the OFF position. Verify the Regulator Gauge is set for the proper pressure for the cylinders being tested.

Attach the test adapter to the cylinder for which you have entered the information. The adapter should engage with 3 to 5 neck threads in order for the cylinder to be safely tested. Cylinders with excessively worn neck threads should be condemned.

5.5.1 Test Procedure (see: CGA C1--1996)

- A. Close and/or verify that the Bleed Valve is tightly CLOSED.
- B. Turn the Water To Pump Valve to the ON position (the pressure gauge will indicate incoming water supply pressure).
- C. Turn ON the Pump Speed Adjustment Valve to pressurize the cylinder to the required pressure for the cylinder being tested.
- D. If the needle on the gauge bounces erratically during pressurization, reduce the speed of the pump with the Pump Speed Adjustment Valve until there is a steady rise from the needle. Erratic movement of the needle could affect the performance of the gauge.
- E. When the gauge indicates that pressurization is within 500 psi of the test pressure, turn the Pump Speed Adjustment Valve toward the OFF position to slow the pump until the desired pressure is reached. A rate of approximately 100 psi per three seconds is recommended.
- F. Upon reaching the desired pressure, turn the Pump Speed Adjustment Valve to OFF. Turn OFF the Water To Pump Valve.
- G. To accurately read the Test Gauge, line the indicator needle up with its mirrored image and read the gauge where the needle and mirror form a single image. Tap lightly on the face of the Test Gauge with your finger to ensure proper placement of the needle pointer.

- H. If the gauge pressure has not reached minimum test pressure, slowly turn the Pump Speed Adjustment Valve to increase the pressure in the cylinder.
- I. Maintain the test pressure for at least 30 seconds, and as long as necessary for complete expansion of the cylinder.
- J. Turn the Bleed Valve counter clockwise to bleed the pressure from the cylinder.
- K. Leave the Bleed Valve OPEN until the next cylinder is ready to test.
- L. Remove the Test Pressure Hose from the cylinder.

Repeat Steps 5.4.4.A through L. for additional cylinders to be tested.

5.4.5 System Shutdown Procedure

The system should be shut-down whenever it will be left unattended for any length of time such as between shifts, overnight and over weekends.

- A. Verify that all valves are in the OFF or HOLD position.
- B. Turn OFF the City Water and Shop Air Supply sources to the system.

6.0 Maintenance And Troubleshooting

6.1 PPT Test Console

Keep the Test Console and components clean and dry and free of dirt and debris.

Regularly inspect the plumbing components of the Test Console for leaks. Also inspect the lines which connect the Test Console to the cylinder and Pump Assembly for leaks.

6.2 Intensifier Pump Assembly

Regularly inspect the plumbing components of the Pump Assembly for leaks.

Pump speed and pressure must be adjusted for the size/rating of cylinders being tested. Refer to Section 5.3.5, for the adjustment procedure.

Replace worn pump seals and packings as needed.

Regularly inspect the filters of the Pump Assembly. Clean or replace as needed.

6.3 Troubleshooting

If you develop what appears to be a problem, please check the following section to identify where the problem might be located. If you should need additional help, please call Galiso, Inc. at (800) 854-3789.

Table 6 - 1 Troubleshooting

PROBLEM	POSSIBLE CAUSE	REMEDY
Pressure Decreasing	1. Leak in Bleed Valve	1. Remove the tubing from the Bleed Valve. If drops begin to form at the elbow or end of the tubing when the system is pressurized, the valve needs to be rebuilt.
	2. Leak in High Pressure tubing	2. Check all connections from the Test Console out to the jacket.
Pressure Increasing	1. Pump continues to run after turning off pump speed control valve.	1. Turn the air to the pump off. If this stops The increase, repair or replace the pump speed control valve.
Pump will not Cycle	1. Low air pressure	1. Check the incoming air pressure.
	2. Restricted air volume	2. Check air lines for contamination and leaks.