

Galiso Dual Acting Pump (GDP-10k)

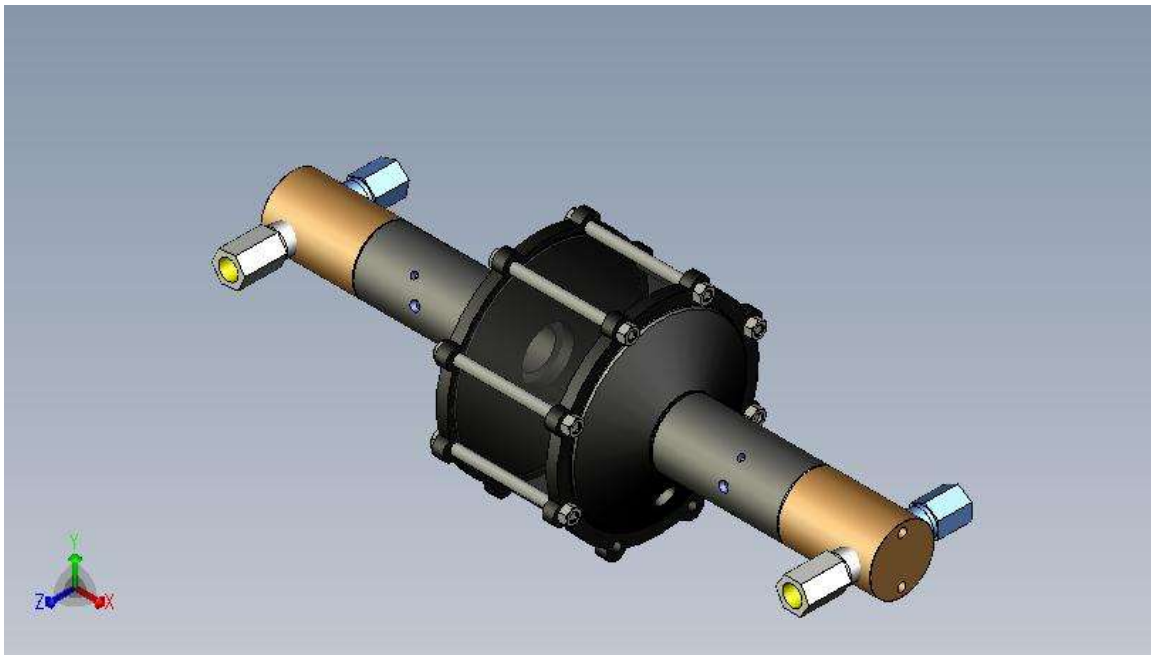

Repair and Maintenance
Component Repair

Parts Explanation

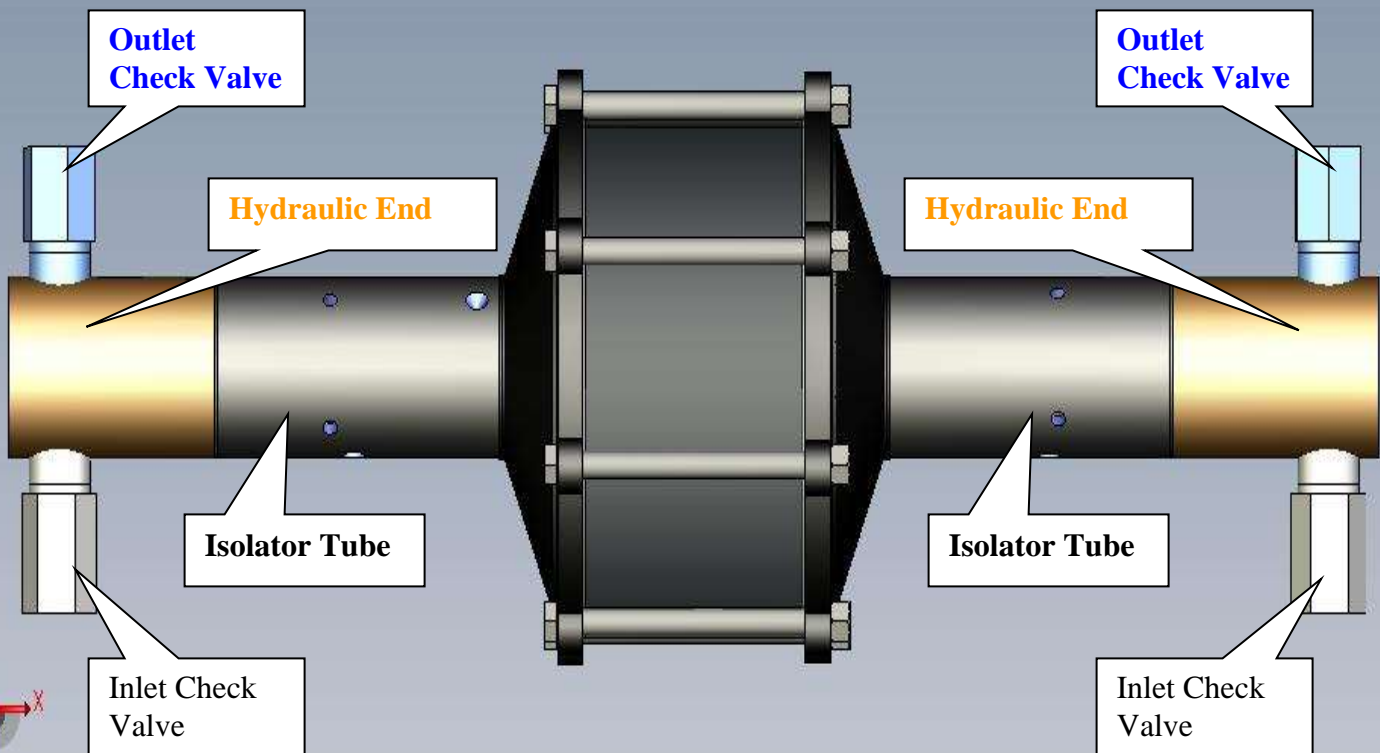

The most common problem in the field with this pump is a drip of water from the isolator tube.

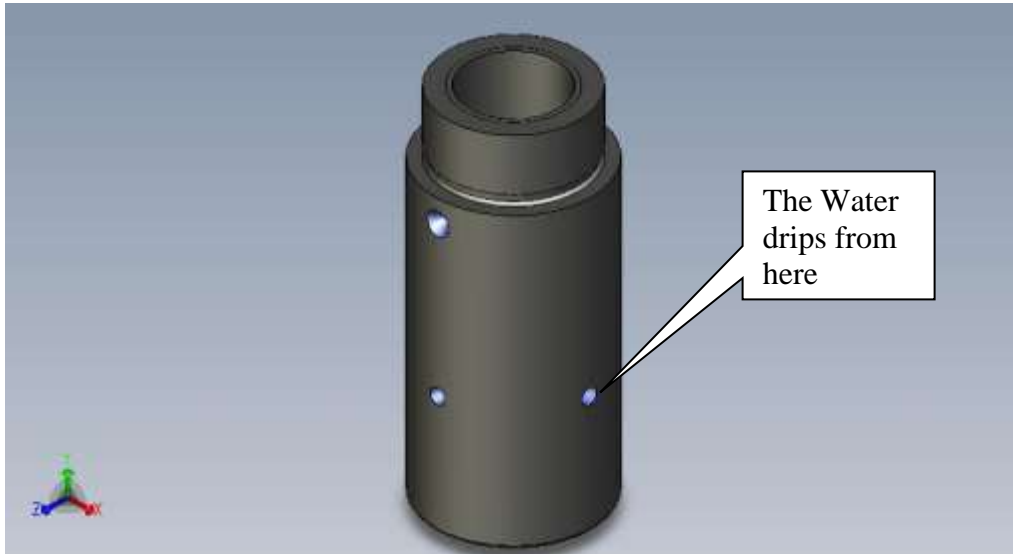

This indicates that the seals in the hydraulic end have excessive wear.

Follow these steps to repair

1. First remove both the high pressure (9/16 wrench) and low pressure (7/8 wrench) tubing from fittings located on the check valves.

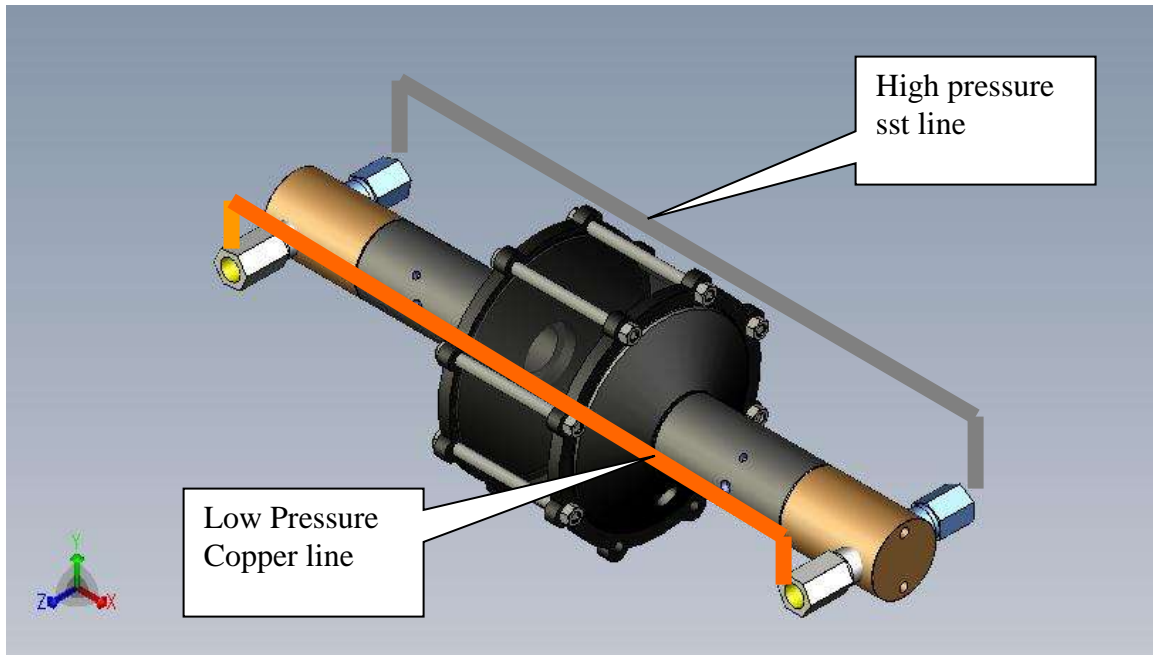

2. Unscrew the hydraulic end assy from the pump

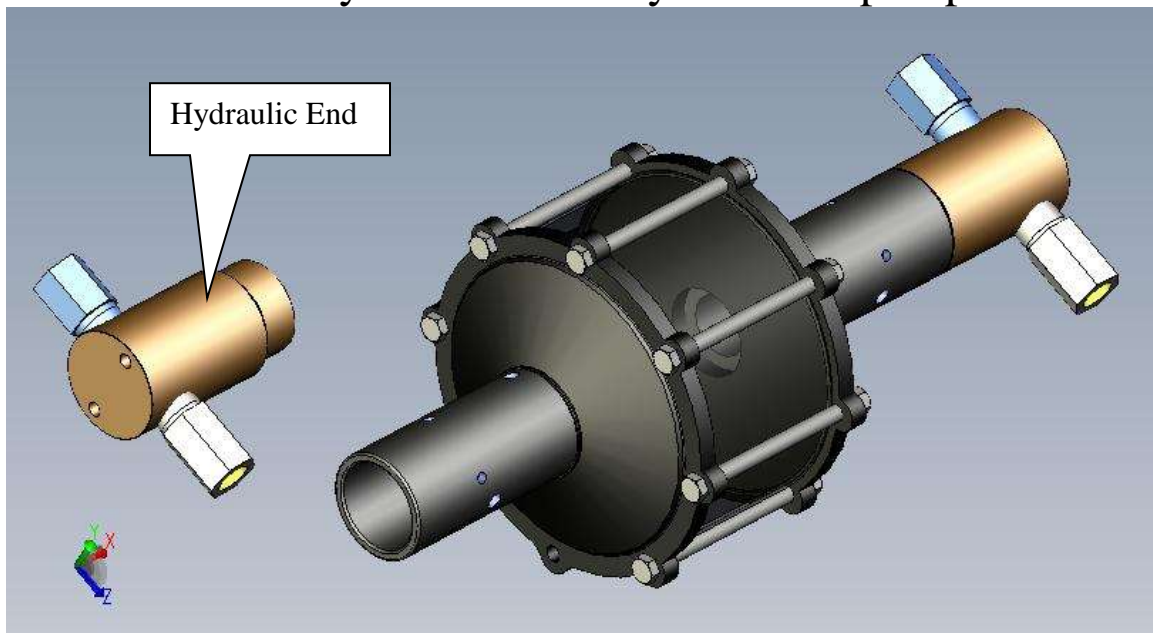

3. Set upright to pick out the old seals

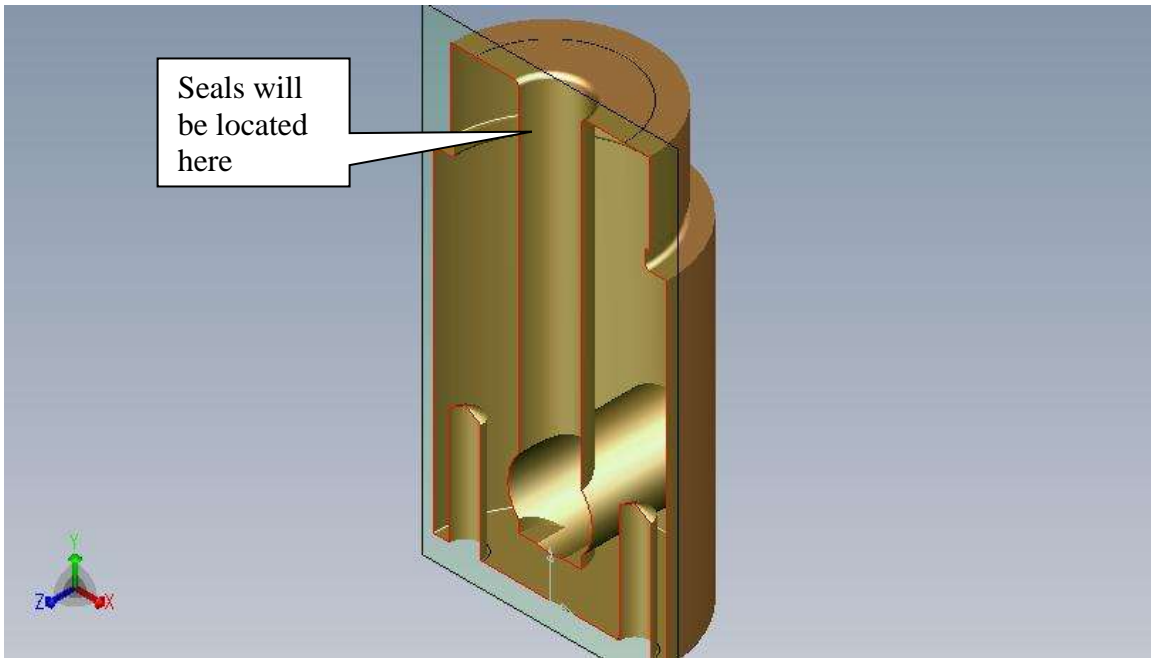

4. Replace existing seals with new and reassemble the pump (when installed the o-ring should be sandwiched between the two Teflon seals)



To repair the check valves of the pump:

1. First remove both the high pressure (9/16 wrench) and low pressure (7/8 wrench) tubing from fittings located on the check valves.

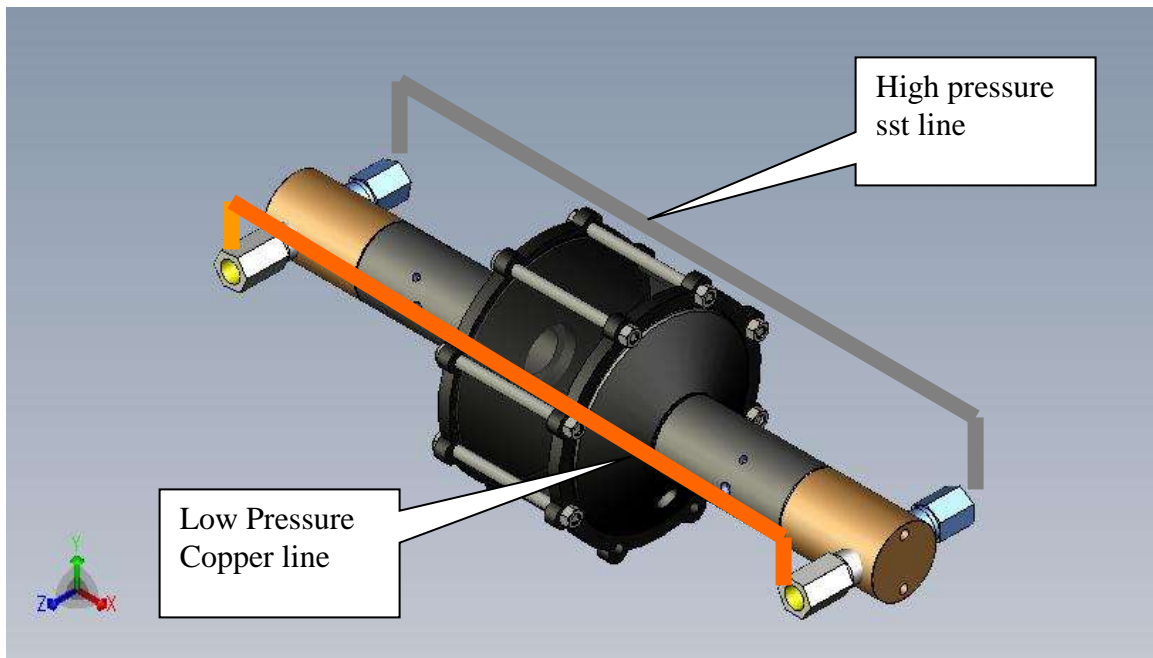

2. Remove check valve

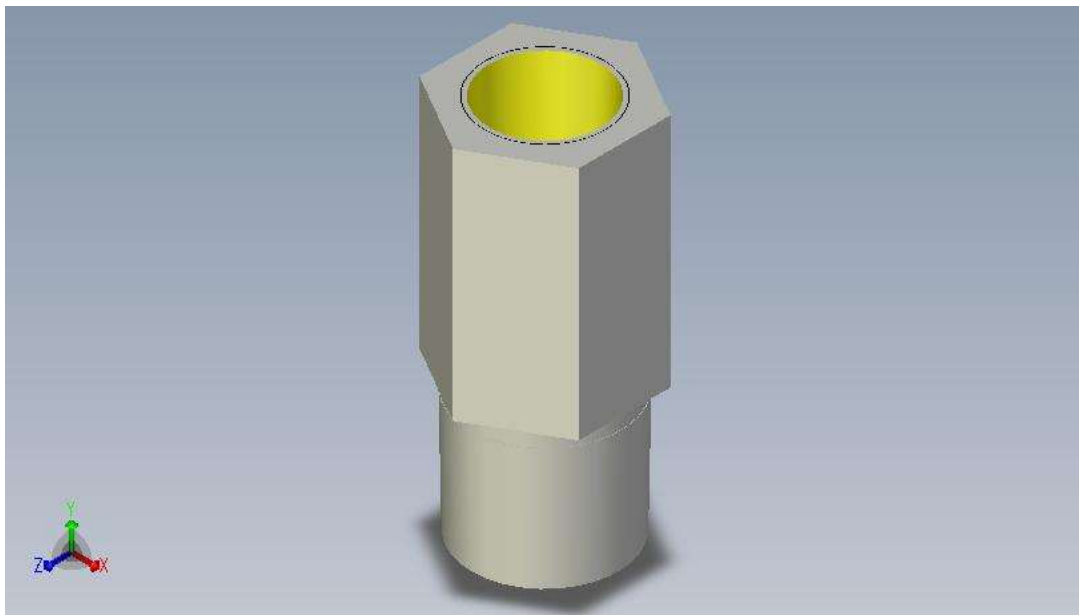

3 The check valve repair kit consists of the following:

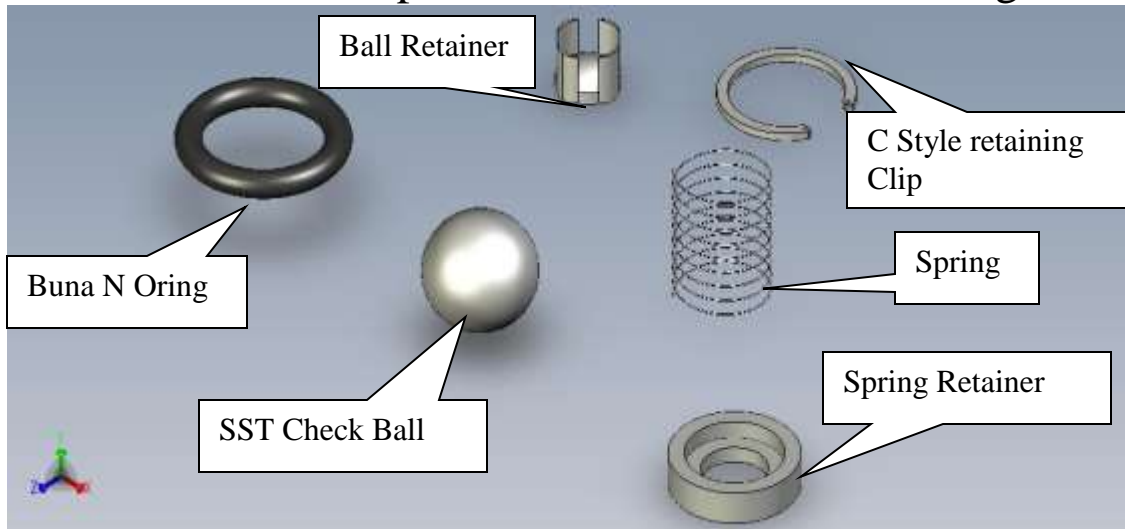

5. Remove C Clip and all Parts.
6. Use O-ring pick to remove O-ring
7. Replace O-ring, grease O-ring with O2 compatible grease
8. Replace all of the hard items and return to service.

To replace the Air seals in the Isolator Tube:

- 1 First remove both the high pressure (9/16 wrench) and low pressure (7/8 wrench) tubing from fittings located on the check valves.

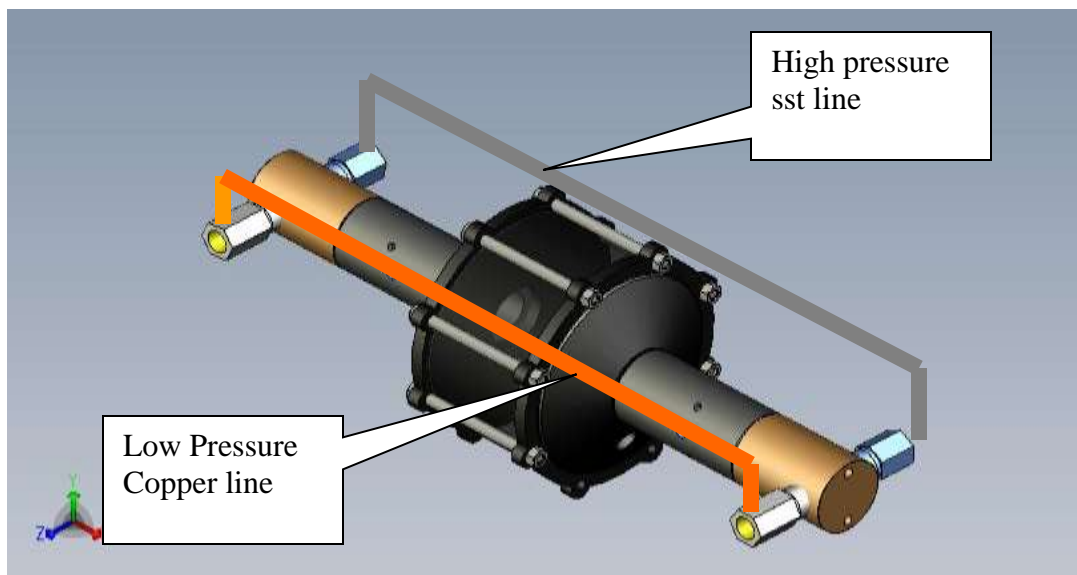

2 Unscrew the hydraulic end assy from the pump

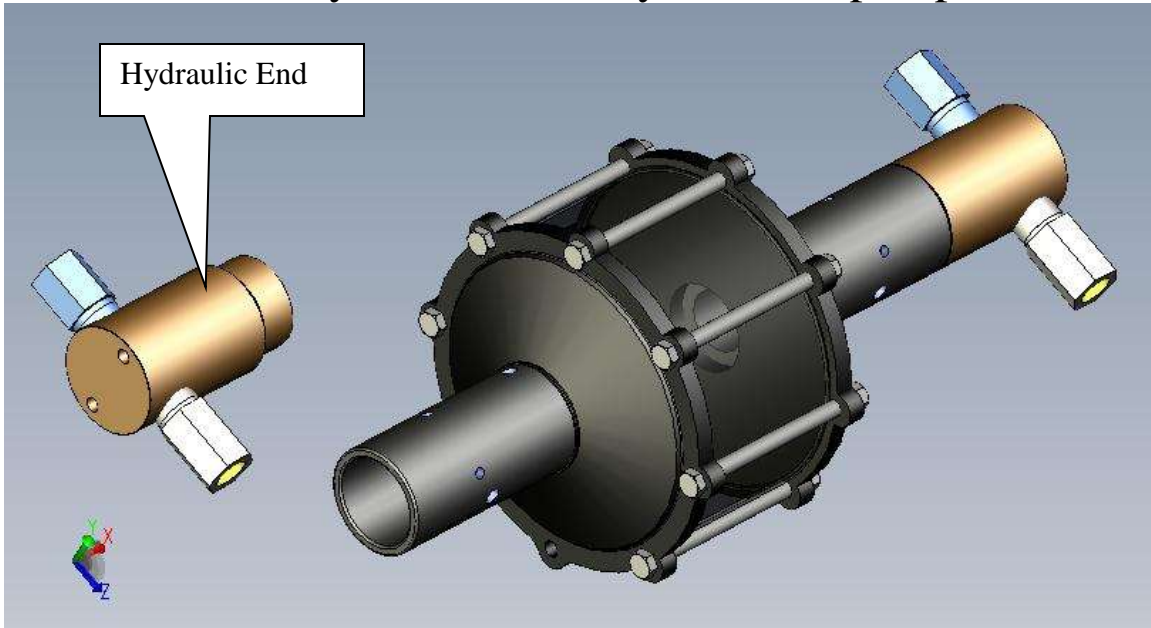

3 Loosen the 1/8" Allen on the end cap assy and unscrew the Isolator tube

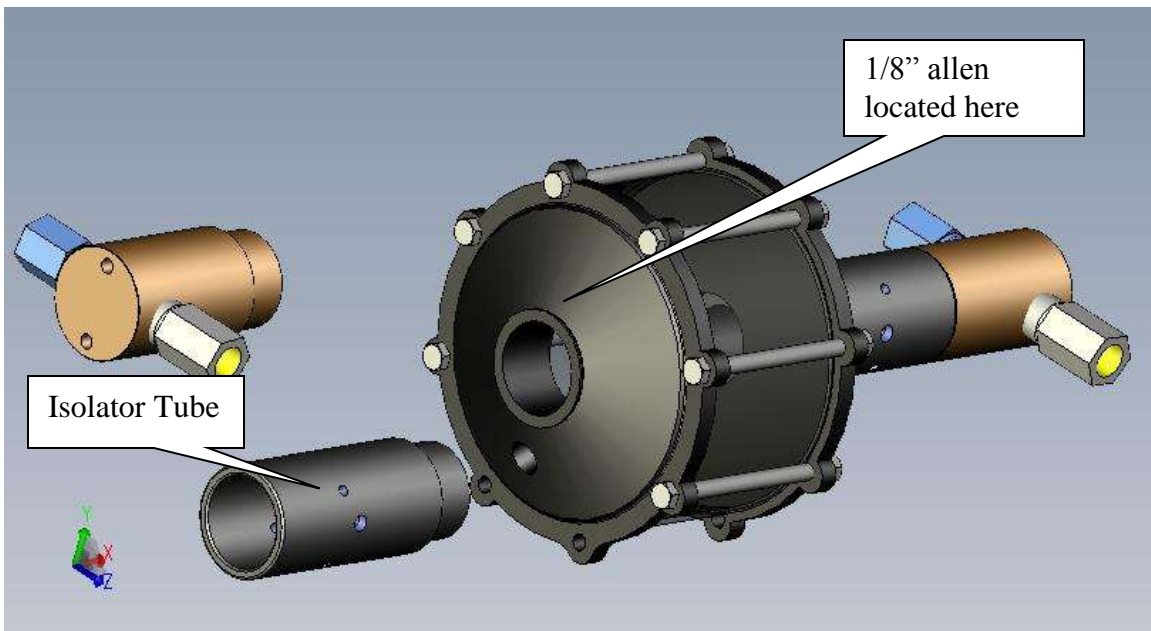

4 Remove old seal with o-ring pick

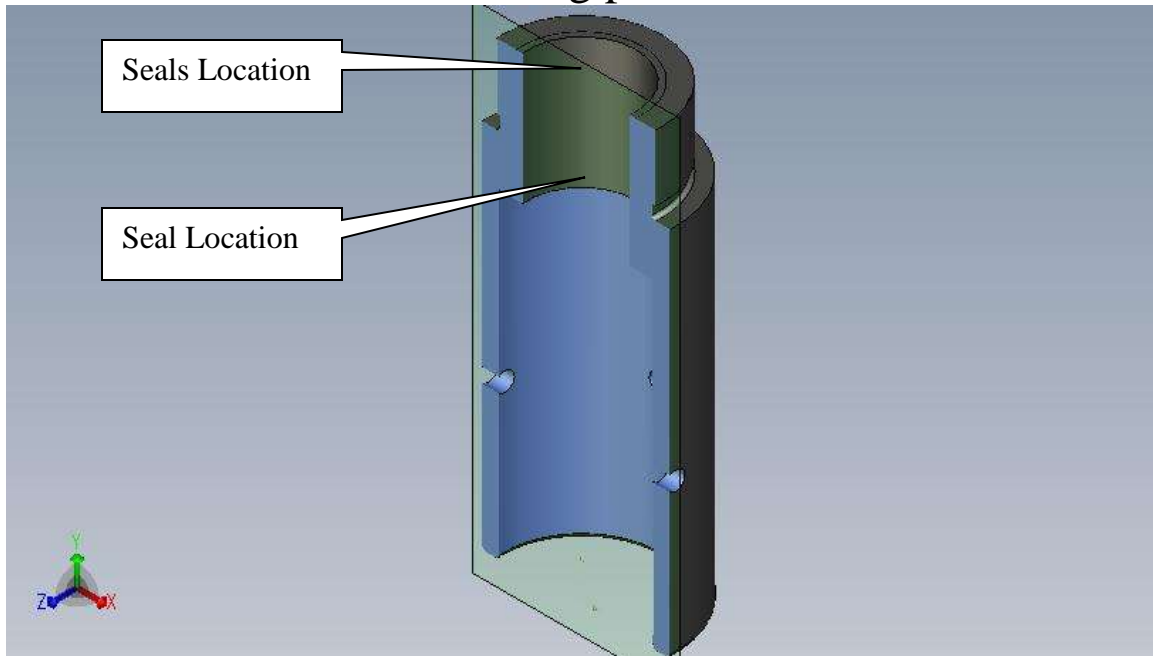

- 4 When installing new seal be sure that the O-ring is installed into the Teflon backup seal prior to installing in the isolator tube
- 5 Lightly bend in one side of the Teflon Backup/O-ring assy to make a “C” shape and install into the Isolator tube. Be sure that the seals are completely in the groove.